

# Test of the ITER Central Solenoid Model Coil and CS Insert

N. Martovetsky, P. Michael, J. Minervini, A. Radovinsky, M. Takayasu, C. Y. Gung, R. Thome, T. Ando, T. Isono, K. Hamada, T. Kato, K. Kawano, N. Koizumi, K. Matsui, H. Nakajima, G. Nishijima, Y. Nunoya, M. Sugimoto, Y. Takahashi, H. Tsuji, D. Bessette, K. Okuno, N. Mitchell, M. Ricci, R. Zanino, L. Savoldi, K. Arai, and A. Ninomiya

**Abstract**—The Central Solenoid Model Coil (CSMC) was designed and built from 1993 to 1999 by an ITER collaboration between the U.S. and Japan, with contributions from the European Union and the Russian Federation. The main goal of the project was to establish the superconducting magnet technology necessary for a large-scale fusion experimental reactor. Three heavily instrumented insert coils were built to cover a wide operational space for testing. The CS Insert, built by Japan, was tested in April–August of 2000. The TF Insert, built by Russian Federation, will be tested in the fall of 2001. The NbAl Insert, built by Japan, will be tested in 2002. The testing takes place in the CSMC Test Facility at the Japan Atomic Energy Research Institute, Naka, Japan. The CSMC was charged successfully without training to its design current of 46 kA to produce 13 T in the magnet bore. The stored energy at 46 kA was 640 MJ. This paper presents the main results of the CSMC and the CS Insert testing—magnet critical parameters, ac losses, joint performance, quench characteristics and some results of the post-test analysis.

**Index Terms**—Cable in conduit conductors, losses, stability, superconducting magnets, testing.

## I. INTRODUCTION

THE 180 t test assembly is shown in Fig. 1. The CSMC consists of an Inner Module, Outer Module, insert coil, and support structure. This is the largest cable-in-conduit conductor (CICC) magnet ever built. It is also the world's largest pulsed magnet that has demonstrated stable operation with ramp rates up to 2 T/s. The conductor for the CSMC and the CS Insert used a heavy wall conduit made of Incoloy 908. This alloy, developed for the Nb<sub>3</sub>Sn CICC applications, has excellent mechan-

Manuscript received September 25, 2001. This work was supported by the U.S. Department of Energy and Government of Japan.

N. Martovetsky is with Lawrence Livermore National Laboratory, Livermore, CA 94550 USA.

P. Michael, J. Minervini, A. Radovinsky, M. Takayasu, and C. Y. Gung are with the Plasma Science and Fusion Center, Massachusetts Institute of Technology, Cambridge, MA 02139 USA.

R. Thome is with General Atomics, San Diego, CA 92186.

T. Ando, T. Isono, K. Hamada, T. Kato, K. Kawano, N. Koizumi, K. Matsui, H. Nakajima, G. Nishijima, Y. Nunoya, M. Sugimoto, Y. Takahashi, and H. Tsuji are with Japan Atomic Energy Research Institute, Naka-gun, Ibaraki-ken, 311-01, Japan.

D. Bessette, K. Okuno, and N. Mitchell are with ITER Joint Central Team, Naka-gun, Ibaraki-ken, 311-0193 Japan.

M. Ricci is with ENEA C.R. Frascati, 00044 Italy.

R. Zanino and L. Savoldi are with Politecnico, Torino, 10129 Italy.

K. Arai is with the National Institute of Advanced Industrial Science and Technology, 1-1-1 Umezono, Tsukuba-shi, Ibaraki-ken, 305-8568, Japan.

A. Ninomiya is with Seikei University, 3-3-1 Kitamachi, Kichijyoji, Musashino-shi, Tokyo, 180-8633, Japan.

Publisher Item Identifier S 1051-8223(02)03616-3.

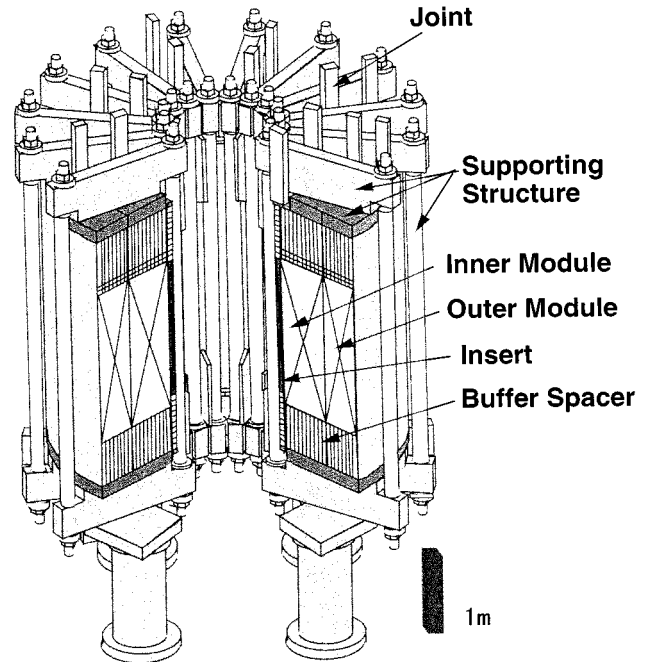

Fig. 1. CSMC and CS Insert test assembly.

ical properties and also has a compatible coefficient of thermal expansion, which helps to more fully utilize the properties of the strain sensitive superconductor.

The test campaign with the CS Insert explored a wide parameter space, with more than 350 runs [1], [2]. The coil and structure instrumentation consisted of more than 500 sensors.

The experiments provided large amount of valuable information on magnet and conductor performance for conditions designed to simulate a fusion magnet environment, as well as much more severe conditions.

Initial test results were presented in [1], [2]. In this paper we place more emphasis on interpretation of the tests results in the light of the post-test analyses. We include unexpected findings and information to be taken into account for the design of future fusion magnets.

## II. MECHANICAL PERFORMANCE

The CSMC, CS insert and support structure were heavily instrumented with strain gauges and displacement sensors to monitor strains and displacements throughout the test program. A major objective for these measurements was to compare the observed coil performance with pretest predictions. As is often the

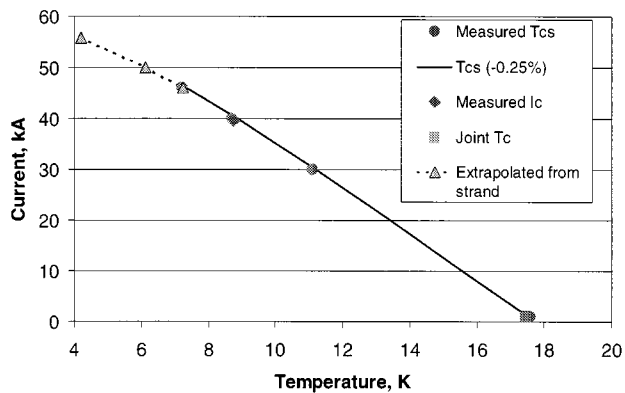

Fig. 2. Current sharing temperature and critical current measurements for conductor 1 A in CSMC.

case with large cryogenic objects, these mechanical measurements presented a large technological challenge.

The CSMC was mechanically preloaded at room temperature to simulate the load conditions for the Central Solenoid. The preload structure was designed to gain an additional preload during cooldown. However, cooldown of the coil did not enhance the preload to the desired extent; this suggests that the difference between the CTE of the stainless steel structure and the winding pack was smaller than predicted by ANSYS models of the coil. During electromagnetic operation, the preload decreased by the full amount indicated by the predictions.

The measured electromagnetic displacements of the CSMC and CS Insert did not correspond well with those predicted by pretest analyses. During the tests, several of the radial displacement sensors developed a significant zero offset in the presence of magnetic field, thus their readings are considered unreliable. The axial displacement sensor structure was also magnetized which may or may not contribute to the fact that the measured axial displacements were roughly twice their anticipated values.

Measurement of the coils' electromagnetic strains was not an easy task either. Discontinuous changes observed in the hoop strain measurements at the inner radius of the inner module suggest that the coupling between the strain gauges and the winding pack was very poor following initial operation of the coil. Although the measured results for most other strain gauge mounting locations roughly paralleled the predicted values, there was sufficient variation between sensors measuring the same nominal behavior to claim a good match between measurement and theory.

Several acoustic emission (AE) sensors were used on the CSMC. The analysis of the AE diagnostics showed that the AE decreased significantly after several charging cycles. During initial charging cycles the AE signals correlated with voltage spikes measured on the conductors, which suggested that the AE signals came from the cable moving inside the conduit under the electromagnetic load. The AE system allowed determining the location of the most intensive signals, which appeared to have been at the ID of the CSMC, at an axial location approximately half way between the mid plane and the coil top.

Despite the difficulties in structural measurements, the CSMC verified in general the validity of the design criteria and

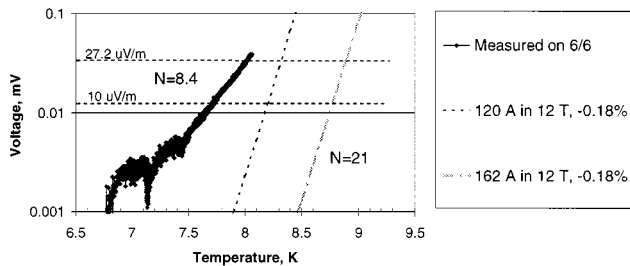

Fig. 3. Voltage-temperature characteristic of the CS Insert before cyclic tests at 40 kA in 13 T field.

provided a valuable data for improvements in modeling of the future fusion magnets. No plastic behavior was noticed in the CSMC operation.

### III. DC PERFORMANCE OF CSMC AND CS INSERT BEFORE CYCLING TESTS

Current sharing temperature ( $T_{cs}$ ) and critical current measurements were carried out on the conductors 1 A, 11 A and the CS Insert. Conductors were wound “two-in-hand,” hence each layer has “A” and “B” conductors.

Current sharing temperature  $T_{cs}$  and critical current  $I_c$  measurements under DC conditions showed that the superconducting properties of the conductor 1 A satisfy the ITER design guidance, which were based on *L. Summers* correlation [3]. Fig. 2 shows DC results measured on the conductor 1 A. As seen from Fig. 2, the current sharing measurement at constant current is consistent with the critical current measurement at a fixed temperature, which suggests that the conductor reached its ultimate performance limit. The fitting parameters, describing the properties of the conductor 1 A are:  $j_c = 593 \text{ A/mm}^2 @ 4.2\text{K}, 12 \text{ T}$ ,  $e = -0.25\%$ ,  $T_{c0} = 18 \text{ K}$ ,  $B_{c20} = 28 \text{ T}$ , at  $10 \mu\text{V/m}$ . These fitting parameters show that the CSMC conductor exceeds the specified strand current density at 12 T and 4.2 K of  $550 \text{ A/mm}^2$ . The cable experienced a very low strain in the conductor resulting in high  $j_c$  because of Incoloy 908 conduit and a proper design. Subsequent post-test analysis showed that the results of the experiment are in a good agreement with more accurate strand characterization by the University of Twente group [4], which indicates no noticeable degradation of the conductor properties within available accuracy.

Conductor 11 A also showed slightly better performance in DC operation than expected, although its short and not well-defined voltage-generating zone inevitably increased the error bar of the test results.

The CS Insert was heavily instrumented and thus had much better accuracy of measurements than the CSMC conductors. DC measurement revealed the following features. First, the measured CS Insert properties exceeded the ITER design specifications, but the strand properties also were significantly higher than specified and higher than the conductor 1 A parameters. Second, the  $N$ -factor of the conductor was significantly lower than the  $N$ -factor of the strands. Fig. 3 shows the measured voltage-temperature characteristic (VTC) of the CS Insert measured on June 6, before cyclic tests. The plot is represented

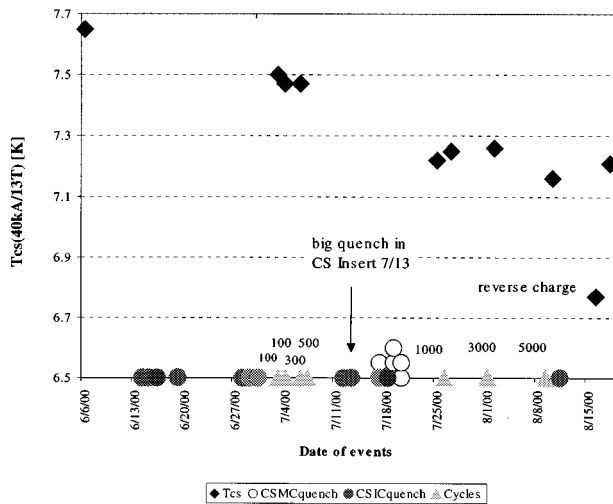

Fig. 4. Evolution of the  $T_{cs}$  in the CS Insert during the test campaign.

in a semi-logarithmic coordinates. Two lines show the expected performance of the conductor based on the strand performance. The line with the lower  $T_{cs}$  corresponds to strands reacted with the heat treatment recommended by the strand vendor; they showed 120 A critical current at  $10 \mu\text{V/m}$  in 12 T field at 4.22 K and  $-0.26\%$  strain [4]. The line with higher  $T_{cs}$  characteristic corresponds to strand witness samples that were heat treated with the CS Insert; their critical current in 12 T field was 162 A. The average  $I_c$  (12 T) measured during strand fabrication was 142 A. The calculated VTC assumed that the conductor was compressed to  $-0.32\%$  strain after the cooldown and stretched by 0.14% due to electromagnetic forces, giving a net strain of  $-0.18\%$ . The calculations also assumed a background field of 13 T. As seen from the plot, the critical properties at low electrical fields seem degraded, especially in comparison with the witness sample. The  $N$ -factor in the conductor, used to describe the transition in the form  $E = AI^N$ , is significantly lower than the  $N$ -factor in the strand [4]. As it is shown in Fig. 3, the  $N$ -factor in the cable is less than half of that for the strand. Such a behavior resembles the reduction of the  $N$ -factor in SC coils like T-15 [5] and the Westinghouse LCT coil [6]. These react-and-wound conductors showed both significant broadening of the transition ( $N$ -factor decrease) and a significant degradation of the superconducting properties. In the case of the CS Insert, the apparent degradation is not so large, especially at higher levels of electrical fields.

This phenomenon has attracted a lot of analytical and experimental effort to explain the mechanism of the  $N$ -factor decrease and the apparent degradation of superconducting properties. This degradation is a very important issue, which directly affects the safety margin and amount of superconductor needed in a CICC. Since the cost of the superconductor in fusion magnets is very high, it is essential to understand the nature of the phenomenon and ways to mitigate the consequences. Working hypotheses include: 1) transformation of the superconducting properties under significant transverse electromagnetic loads, 2) nonuniform current distribution in the cable due to unavoidable differences in contact resistances between individual strands and the facility terminal and 3) other hypothesis.

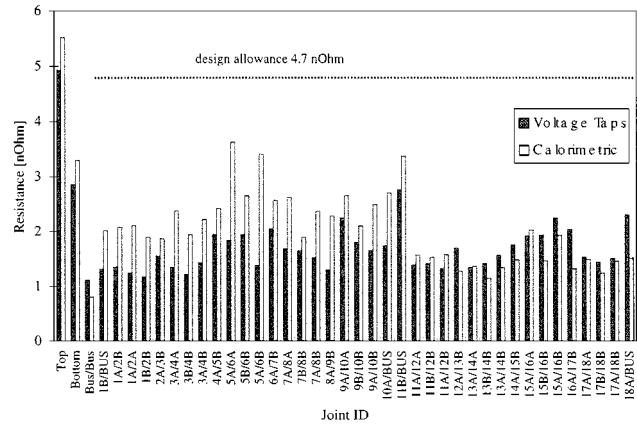

Fig. 5. Distribution of the joint resistances measured by electrical and calorimetric methods at 46 kA.

Some analyses indicate that the degradation is within measurement uncertainties and may be nonexistent. A substantial experimental effort will be focused on this phenomenon during testing of the remaining inserts and also in smaller scale experiments in other facilities.

#### IV. EFFECT OF CYCLIC TESTING ON THE CS INSERT

An important component of the test campaign was cyclic testing of the CS Insert—the current in the CS Insert was cycled from 0 to 40 kA in the slowly decaying, approximately 13 T, background field of the CSMC.

Totally, 10 000 current cycles were performed. Unfortunately, the logistics of the test campaign did not allow us continuous cyclic testing; other experiments, like quench propagation and ramp rate limitation studies were performed in between some cycles, as indicated in Fig. 4. To monitor the change in the insert properties, measurements of  $T_{cs}$  at 13 T at 40 kA and loss measurements were carried out. Fig. 4 shows the evolution of the  $T_{cs}$ . It appears from Fig. 4 that quenches, not cyclic testing, could have been more responsible for degradation of the properties, since there was a very little degradation from cycles 1000 and 10 000 and both noticeable drops in  $T_{cs}$  happened when several quenches occurred in between the measurements. However it is impossible to rule out conclusively from the available information that the first 1000 cycles did not contribute to the properties degradation. Recent work dedicated to the effect of load cycling on CICC properties showed that cycling loading could degrade Nb3Sn strand properties [7]. So far we have been unable to come up with an explanation for a degradation mechanism resulting from quenches, since the maximum quench temperature in the cable always remained below 110 K. The CSMC design criteria called for maximum quench temperatures below 150 K. We considered that it was safe to allow the cable reaching this temperature as a result of quench for a short time. Although a proper safety margin can mitigate the degradation of the conductor properties, it is important to obtain detailed information about causes of this change of conductor properties to improve efficiency of the magnets and possibly to reduce their cost.

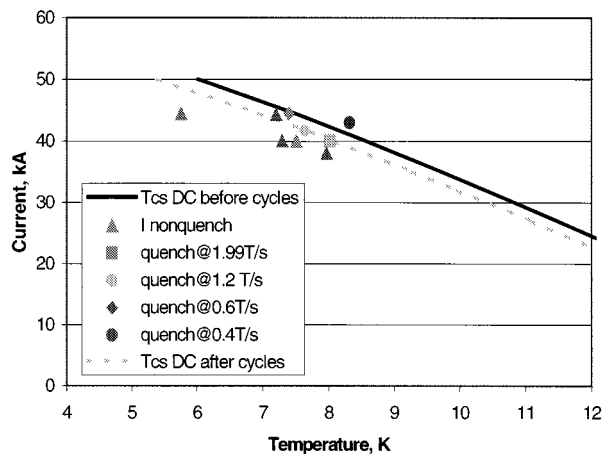

Fig. 6. Comparison between  $T_{cs}$  measured in DC conditions and the measured temperature in the CS Insert immediately before quench in ramp rate sensitivity tests.

## V. PERFORMANCE OF THE JOINTS

Joints in CICC magnets are always critical components, but for the Central Solenoid they also have to work with low losses, low resistance and high reliability in a relatively high and varying magnetic field.

Two types of 46 kA joints were developed for the CSMC and tested during an extensive R&D program [8], [9]: a lap joint and a butt joint. The lap joints between the layers in the Inner Module were soldered, the butt joints in the Outer Module were diffusion bonded under high temperature and pressure, and the termination joints to bus bars were connected with Indium wires in the interfaces, crushed by high pressure. The requirements to have a low resistance, low DC and AC losses and high reliability in a high field and high  $dB/dt$  environment made the joints quite complicated. During the R&D phase we discovered that electrical measurements not always accurately reflect the total joint resistance due to high sensitivity to the details of the voltage distribution in the joint and the adjacent conductor. To verify the electrical measurements we also used the calorimetric method to measure the heat generated by the joint. Results of both measurements are shown in Fig. 5. Most of the joints showed resistances between 1 and 2 nOhm, comfortably below the design allowance of 4.7 nOhm. Only one joint on the top of the CS Insert to the bus bar was slightly higher than that allowance, but these joints are better cooled than layer-to-layer joints. This joint was one of the dismantlable joints with squeezed In wire, which was expected to have a little higher resistance than the soldered one. Other dismantlable joints to bus bars had low resistance (see Fig. 5). In no tests, including much more severe conditions than foreseen for ITER were joints a limiting factor for the CSMC or CS Insert. This experience proves that the CICC joints can be made with low losses, low resistance and high reliability.

## VI. RAMP RATE LIMITATION STUDIES

We studied the ramp rate sensitivity up to 2 T/s both for the CSMC and the CS Insert. Several CICC in the past had significant problems at high ramp rates, which were attributed to

the nonuniform distribution of the current between the cable strands. The target operation for the CSMC was 0.4 T/s ramping to 13 T. Pre-test analyses predicted that if current distribution in the cable were uniform the maximum  $dB/dt$  to 13 T charge would be 1.2 T/s.

The CS Insert withstood a 1.2 T/s ramp to 13 T, while the CSMC conductor 1B quenched in that run at about 11.8 T due to slightly higher and less uniform losses than in the CS Insert. This performance is very close to the pre-test prediction.

The CSMC was successfully charged to 38 kA at 1.9 T/s; the CS Insert had to be warmed to 6.5 K to quench at 40 kA and 1.9 T/s ramp. To establish if quench in the CSMC and CS Insert at high  $dB/dt$  results from instability or from simple heating due to losses, we calculated the maximum temperature in the conductor at the moment of the quench. We used no-quench runs and the outlet/inlet temperature and pressure data for the analysis and also the pressure data from the center pressure tap of the CS Insert. Fig. 6 shows the result of this comparison for the CS Insert and indicates that the losses and corresponding heating are mostly responsible for the quench. Similar analysis was performed for the CSMC as well. The analysis shows that electromagnetic instability and nonuniform current distribution in the conductor are negligible up to 0.6 T/s in the CSMC and up to 1.2 T/s in the CS Insert.

The deviation of the maximum pulsed current from the DC performance starts to grow at higher  $dB/dt$  rates. These results and many other successful shots simulating the ITER operation scenarios (including plasma initiation, disruptions and much more severe conditions) showed that the CS Insert and CSMC had relatively low ramp rate sensitivity up to 2 T/s, which suggests good current uniformity and therefore high stability in such a large cable.

## VII. AC LOSSES

Loss measurement in the CSMC and the CS Insert was an important element of the Test Program. We measured losses from the very beginning of the test campaign and monitored the losses during the whole duration of testing. A more detailed description of the loss behavior is given in [1]. Most of the measurements were performed using a cycle with a slow charge to 36.8 kA and 20 s discharge on a dump resistor. Testing the CSMC and the CS Insert gave us a rare opportunity to study losses in long conductors. It was known from previous experiments that short sample loss measurements do not always represent the losses in a magnet. In addition, the scatter in the coupling loss measurements on the short samples of relevant sub-scale and full-scale ITER conductors during the R&D effort was very significant: the coupling loss time constant varied from several milliseconds to 30–50 ms per unit of strand volume.

### A. Hysteresis Losses

Hysteresis losses in layers 1–4 of the Inner module were up to 2 times higher than expected from the averaged strand data, while layers 5–8, which used the internal tin design strands, showed significantly lower losses than expected. The losses in layers 9–18 were in line with expectations. The discrepancy between measurements and expectations grew with increasing am-

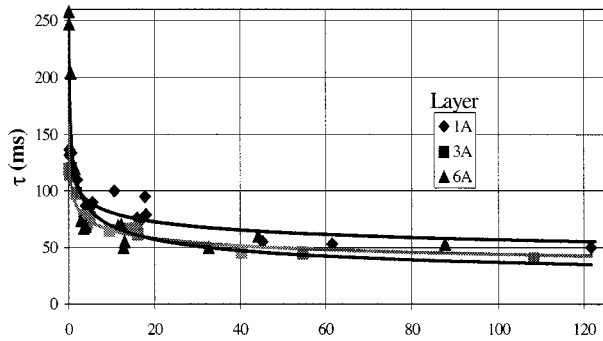

Fig. 7. Reduction of the coupling loss time constant with cycles.

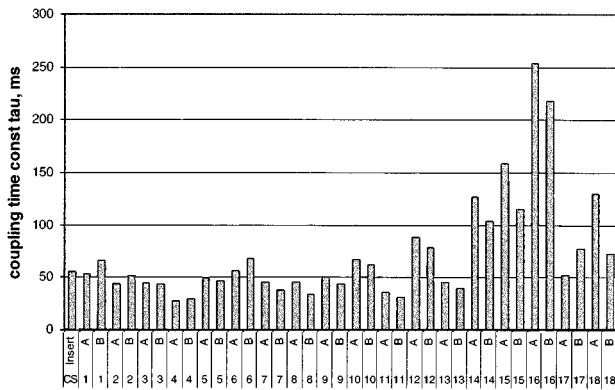

Fig. 8. Coupling time constant in the CSMC and CS Insert measured on 6/27/00.

plitude of the cycle. The contribution from Joule heat generation from the joints in a full cycle to 46 kA was overwhelming, which jeopardized the accuracy of measurements. Judging by these results, both bronze process and internal tin strand designs are acceptable for the Central Solenoid despite higher hysteresis losses in the internal tin strands.

### B. Coupling Losses

Coupling losses in the CSMC reduced significantly as the number of operating cycles grew. After several tens of cycles the losses saturated in the inner layers of the Inner module and the CS Insert, and continued to decrease in the outside layers. This behavior correlates well with the intensity of electromagnetic loading of the cables, described in [1], which assumes that electromagnetic forces gradually break low resistance contacts between the strands in the cable. Fig. 7 shows the decrease of the losses with cycling. The saturation time constant corresponds to the highest of the values measured on short samples in the R&D program, and leads to the conclusion that there were no long length coupling loops in the cable, with long time constants, that typically yield high losses. The Fig. 7 correlation also leads to the conclusion that the coupling loss time constant in all CSMC conductors will be about the same after a large enough numbers of cycles despite different strand designs and slight variation of the chrome plating and cabling patterns.

The distribution of the coupling losses in the coil is presented in Fig. 8 which shows that the layers that are exposed to a lower field, and thus lower electromagnetic forces in the Outer Module (layers 11–18), have higher coupling losses time constant  $\tau_c$ .

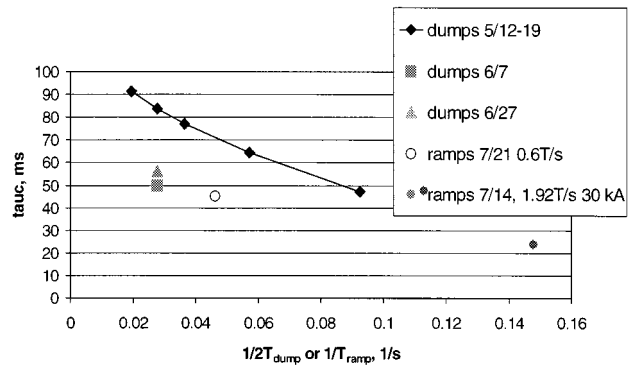

Fig. 9. Decrease of the effective coupling time constant with reduction of the ramp time (increase of the  $dB/dt$ ) in exponential discharges and trapezoidal cycles in conductor 1 A of CSMC.

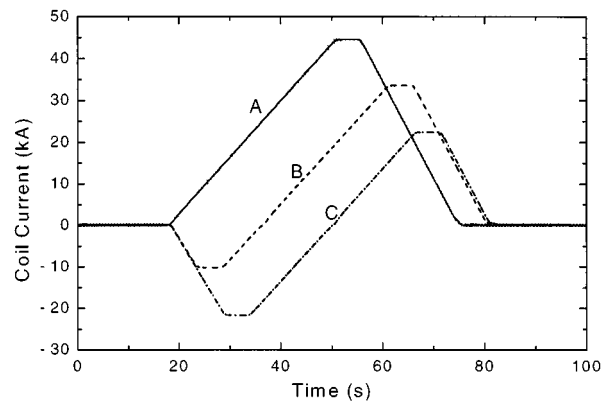

Fig. 10. Coil current patterns in bipolar operation used to study effect of lateral force on losses.

The  $\tau_c$  continues to decrease in these layers even after several tens of cycles, while layers with higher lateral forces reach saturation after several tens of cycles (see Fig. 7) [1]. We believe that the layers with a lower lateral force need more cycles to break the low resistance links between the strands.

The coupling loss time constant also showed a clear dependence on ramp rate,  $dB/dt$ , and amplitude. As the dump time decreased (or ramp up and down times decreased in trapezoidal cycles), the coupling time constant decreased as well. In other words, the coupling time constant did not remain constant versus the effective  $dB/dt$  rate. Fig. 9 shows the decrease of the effective coupling time versus dump time (or ramp time). Such behavior remains to be understood, it does not seem to follow the classic shielding pattern, when the time of the external field change becomes comparable to the coupling time constant. However, this result does explain how similar conductors can have a wide variety of the coupling time constants depending on the amplitude and the rate of the magnetic field change. It also suggests that the actual losses in the tokamak magnet system will be lower than conservatively estimated from slow and large amplitude waveforms.

Although electromagnetic loading seemed to decrease losses, by breaking the coupling links, we also saw that losses in a cable squeezed by electromagnetic force increase as the force increase. A set of experiments was performed as shown in Fig. 10 with equivalent pulse amplitudes but different offsets

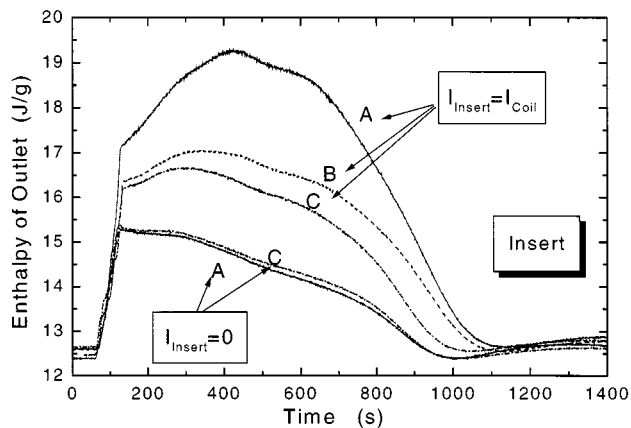

Fig. 11. Measured enthalpy at outlet of CS Insert in bipolar operation.

about zero. If lateral force were not a factor, we would have expected the losses be similar for all three cycles waveforms A, B, and C, with slightly higher losses for run C, due to higher hysteresis losses about zero field. If lateral force does reduce the contact resistances between the strands as was demonstrated in earlier experiments [10], we would have seen losses in cycle A to be higher than those for the B and C waveforms. Fig. 11 shows clearly, that the lateral force does increase the losses significantly. In the absence of transport current, when there are no lateral forces, the difference between cycles A and C is small, as expected.

Therefore the lateral force on a CIC has at least two effects on coupling losses—on one hand it breaks the coupling links between the strands and reduce the losses, on the other hand it generates a high pressure on the cable that increases the losses in the cable. Both of these effects should be taken into account in future designs.

### VIII. OTHER TESTS

Several other tests were performed on the CSMC and the CS Insert during the test campaign. Unique data were obtained on the thermohydraulic behavior of CICC, maximum hot spot temperature versus deposited Joule heating in the cable, stability tests against inductive heater pulses, normal zone propagation in different regimes including clear observation of thermohydraulic quench-back, and performance of the cryogenic system during powerful shots, including quench handling. These system performance data are invaluable for

efficient design of future superconducting systems. Some of the thermohydraulic and stability analyses are presented in [11].

### IX. CONCLUSION

All goals of the CSMC project were achieved successfully. The design criteria and technology feasibility of large, pulsed field CIC magnets were verified. Testing revealed a significant amount of new information, which will help to improve the technical performance and cost efficiency of future fusion magnets.

### ACKNOWLEDGMENT

The authors are grateful to all organizations and individuals who contributed to the successful construction of the CSMC, the CS Insert and the test facility. They also thank all the researchers, who participated in testing, in post-test analyses and in many discussions on the CSMC test results.

### REFERENCES

- [1] N. Martovetsky, P. Michael, and J. Minervini *et al.*, "First test results on ITER CS model coil and CS Insert," in *Proc. 14th Topical Meeting on the Technology of Fusion Energy*, vol. 39, N2, part 2, FUSTE 8 (3) 291-1166, Mar. 2001, pp. 359-367.
- [2] N. Martovetsky, P. Michael, and J. Minervini *et al.*, "ITER CS model coil and CS insert test results," *IEEE Trans. Appl. Superconduct.*, vol. 11, no. 1, pp. 2030-2033, Mar. 2001.
- [3] L. T. Summers, M. W. Guinan, J. R. Miller, and P. A. Hahn, "A model for the prediction of Nb3Sn critical current as a function of field temperature, strain, and radiation damage," *IEEE Trans. MAG-27*, no. 2, p. 2041, 1991.
- [4] A. Godeke, H. Krooshoop, H. G. Knoopers, and H. H. J. ten Kate, "Wide temperature and field scaling relations in Nb3Sn ITER strands," University of Twente, UT-NET/EFDA 2000-5, Final report to NET, Sept. 2000.
- [5] *Superconducting Magnet Systems for Tokamaks*. Moscow: Russian Scientific Center, Kurchatov Institute, 1997, Chief Editor—Chernoplekov.
- [6] L. Dresner, D. T. Fehling, and M. S. Lubell *et al.*, "Stability tests of the Westinghouse coil in the international fusion superconducting magnet test facility," *IEEE Trans. Magn.*, vol. 24, no. 2, pp. 779-782, Mar. 1988.
- [7] P. Bruzzone, A. Fuchs, B. Stepanov, and G. Vecsey, "Performance results of Nb3Sn cable in conduit conductors under cyclic load," in *MT-17 conf.*, paper TUOR1A4-01.
- [8] N. Martovetsky, J. Jayakumar, R. Manahan, and P. Michael *et al.*, "Development and test of the ITER conductor joints for the central solenoid," in *Annual American Nuclear Society Meeting*, Nashville, June 1998.
- [9] Y. Takahashi, Y. Nunoya, and G. Nishijima *et al.*, "Development of 46-kA Nb3Sn conductor joint for ITER model coils," *IEEE Trans. Appl. Superconduct.*, vol. 10, no. 1, pp. 580-583, Mar. 2000.
- [10] M. Takayasu, "Resistance versus lateral force measurements," private communication.
- [11] R. Zanino, L. Savoldi, and E. Salpietro, "Reports presented at Cryogenic Engineering Conf.," Madison, July 2001.